

Hava soğutmalı kondenserli **Soğuk su üretici gruplar**

Air cooled Water chillers

Vidalı kompresörlü • Mikroişlemci kontrollü

Screw compressors • Microprocessor controlled

R134a

Klima sistemleri,

For air-conditioning systems,

Proses soğutmaları,

Process cooling,

Sanayi tesisleri ve

Industrial plants and

Muhtelif maksatlar için

Various purpose

HİDRONİK KİT OPSİYONLU / OPTIONAL HIDRONIC KIT

SOĞUK İKLİM KİTİ OPSİYONLU / OPTIONAL COLD CLIMATE KIT

ADYABATİK SOĞUTMA OPSİYONLU / OPTIONAL ADYABATIC COOLING



Kapasite aralığı

Capacity range

112,7 kW - 769,7 kW

Cihaz Tanımı *Unit Description*

ERBAY Soğuk Su Üretici Grupları, EN ISO 9001:2015 Kalite Yönetim Sisteminin uygulandığı fabrikamızda dış ortamda çalışacak ve kapasite tablosundaki soğuk su çıkış sıcaklıklarını verecek şekilde dizayn edilmiştir. Soğutma Gruplarımız fabrikamızda her türlü boru ve kablo bağlantısı, gaz-yağ şarjı ve gerekli testleri yapılmış olarak ve yerine yerleştirmeye hazır halde teslim edilirler. Soğutma Gruplarımız sağlık emniyeti ve güvenlik gereksinimleri konusunda Avrupa Birliği direktiflerine ve ilgili harmonize standartlara uygundur.

Aşağıdaki kısımlardan müteşekkil olan Soğutma Gruplarının kapasiteleri 112,7 kW ile 769,7 kW arasında değişmektedir.

Soğutma Kompresörü : R134a gazı ile çalışan, isteğe göre 1 veya 2 adet yarı kapalı kompakt vidalı (semi-hermetic compact screw) kompresör kullanılmaktadır. Vidalı kompresör yapısı gereği uzun müddet bakım gerektirmesizin çalışmaktadır. Hareketli parçaların az olması sebebiyle bakımı kolay ve ekonomiktir. Vidalı Kompresörler ; basma-kapama vanası, basma hattındaki akışkanın geri dönüşünü engelleyen check-valf, yağ seviye switchi, yağ gözetleme camı, yağ ayırıcı, filtre, karter ısıtıcı, kapasite kontrol solenoidleri, titreşim takozları, motor koruma rölesi ve PTC sensörleri ile techiz edilmiştir. Gerekli şebeke gerilimi; 3 x 400 V, 50 Hz' dir.

Kondenser (Yoğuşturucu) : Hava Soğutmalı Kondenserler bakır boru ve alüminyum lamelli olarak imal edilmektedir. Soğutucu akışkanın yoğuşmasını sağlamak üzere motoru ile direkt akuple yüksek verimli, aşırı akım koruma röleli, sessiz yataklı aksiyal fan cihaz üzerine monte edilmiştir.

Evaporatör : Shell & Tube tipinde imal edilen direkt genişlemeli evaporatörler özel yüksek verimli bakır boruların çelik ayna deliklerine özel işlem ile tesbit edilmesi suretiyle üretilmiştir. Boru demetinin sökülebilir olması bakım ve temizlik imkanı sağlar. EN 14276-1 ve EN 13445 standartlarına uygun olarak imal edilen evaporatörler su ve glikol çözeltilerin soğutulması için tasarlanmıştır. Evaporatörlerin dış yüzeyi ve kompresör emiş hatları uygun kalınlıkta izolasyon malzemesi kullanılarak izole edilmektedir.

Elektrik Kumanda Panosu : IP54 koruma sınıfına göre tasarlanmıştır. Cihazın tam otomatik ve güvenli olarak çalışmasını sağlayacak şekilde güç ve kumanda tarafları olmak üzere iki kısımdan müteşekkildir. Pano yeterli miktarda kontaktör, termik, sigorta ve şaltele ile techiz edilmiştir. Cihazın panosu ve cihaz içi kablo tesisatı EN 60204-1 standartına uygundur. Gerekli şebeke gerilimi; 3 x 400 V, 50 Hz' dir.

Mikroişlemci Kontrol Sistemi : Cihazda kullanılan mikroişlemci kontrol sistemi sayesinde su giriş ve çıkış sıcaklıkları, emme ve basma tarafındaki gaz basınçları, evaporatörlerde oluşan aşırı ısıtma (superheat) sıcaklığı, kompresörlerin çalışma zamanları, oluşan tüm arızalar ve geçmişte vukubulan tüm arıza kayıtları ekranda digital olarak görülebilmekte ve kolaylıkla kapasite kontrol yapabilmektedir. Ayrıca dış hava sıcaklığına bağlı olarak kondenser fanlarının otomatik olarak devreye girip çıkması ve her kompresörün çalışma sürelerinin dengede tutulup, cihazın optimum verimde çalışması sağlanmaktadır.

Soğutma Devresi Elemanları : Cihazın otomatik ve güvenli şekilde çalışması için elektronik genişleme valfi, drayer-filtre, gözetleme camı emniyet ventili, su akış kontrol otomatığı, alçak ve yüksek basınç duyar elemanları ve soğutma valfleri konmuştur.

ERBAY Water Chillers are designed to outdoor installation and provide chilled water leaving temperatures which are given on capacity tables in our factory carrying out EN ISO 9001:2015 Quality Management System. The Units are supplied to ready for installation. All connections, oil and refrigerant charge and required tests are made in our factory. Our units are in conformity with health and safety requirements of European Union directives and relevant harmonized standards.

The capacity of the Units varying between 112,7 kW and 769,7 kW and it's composed of the following parts;

Cooling Compressor : 1 or 2 pieces semi - hermetic compact screw compressors, working with R134a refrigerant are used according to customer request. Screw compressors as it's characteristics can operate without maintenance need for a long time. Maintenance of the screw compressors are quite simple because of the less amount of the moving parts in it. Screw compressors are equipped with discharge shut-off valve, check -valve that prevents to return back of the refrigerant from the discharge line, oil level switch, oil sight glass, oil separator, oil filter, crankcase heater, capacity control solenoids, vibration dampers, motor protection device and temperature sensors (PTC). Required power supply is 3 ph, 400 V, 50 Hz.

Condenser : Air cooled condensers are manufactured by pipes and aliminum fins. Current overload protected, high efficient direct drive axial fans which have noiseless bearing are mounted on the Unit to provide condensation of the refrigerant.

Evaporator: Direct expansion evaporator is manufactured in Shell & Tube form and special high efficient copper tubes are fixed to steel tubesheet holes with tube expander method. It's allowed to maintenance and clean up because of the removable tube bundle. Evaporators are in conformity with EN 14276-1 and EN 13445 standarts and designed for chilling water and glycol brines. External surface of evaporators and suction lines are insulated with insulation material with suitable thickness.

Electrical Control Panel : The panel is designed to IP54. To operate the Unit automatically and securely, the panel is composed of two different section. The first section is power section and the other one is control section. The panel is equipped with enough number of contactors, thermics, fuses and on-off switches. The panel and wiring are in conformity with EN 60204-1 standart. Required power supply is 3 ph, 400 Volt, 50 Hz.

Microprocessor Control System : Microprocessor control system is used on the Unit. By means of this; entering and leaving water temperatures, refrigerant pressures on the suction and discharge lines, occurred superheat temperature, operating times of compressors, all faults occurred on the system and all alarm history can be seen on the digital screen and also capacity control can be made easily. Besides condenser fans are controlled automatically depending on the ambient temperature and the operating times of each compressor is balanced so optimum efficient operation of the Unit is provided.

Components of the Cooling Circuit : To operate the Unit automatically and securely; electronic expansion valve, drier-filter, sight glass, relief valve, flow - switch, low and high pressure transmitters and shut-off valves are included.

Teknik Özellikler *Technical Specifications*

CİHAZ TİPİ TYPE	EBHV - 113A.1	EBHV - 150A.1	EBHV - 185A.1	EBHV - 220A.1	EBHV - 275A.1	EBHV - 330A.1	EBHV - 360A.1	EBHV - 420A.1	EBHV - 490A.1	EBHV - 560A.1	EBHV - 630A.1	EBHV - 695A.1	
													(1)
Nominal Kapasite (kW) <i>Nominal Capacity</i>	R134a	(1)	124.5	164.8	205.8	242.5	304.3	362.3	397.7	462.1	539.9	619.3	769.7
		(2)	112.7	149.1	186.2	219.4	275.3	327.8	359.8	418.1	488.5	560.4	631.3
Nominal Kompresör Gücü (kW) <i>Nominal Power Input of the Comp.</i>	R134a	(1)	27.5	36.3	43.1	51.0	64.2	76.2	84.3	94.5	111.5	124.9	155.6
		(2)	31.7	41.9	49.8	58.9	74.2	88.0	97.4	109.1	128.9	144.3	163.8
COP	R134a	(1)	4.53	4.53	4.78	4.76	4.74	4.76	4.72	4.89	4.84	4.96	4.95
		(2)	3.56	3.56	3.74	3.75	3.71	3.73	3.69	3.83	3.79	3.88	3.87
Kompresör Adedi / Number of Compressors		1	1	1	1	1	1	1	1	1	1	1	
%25 - %100 Sürekli Kapasite Kontrol / %25 - %100 Infinite Capacity Control													
Kapasite Kontrol / Capacity Control		2 x 1,8	2 x 1,8	2 x 1,8	4 x 1,8	4 x 1,8	6 x 1,8	6 x 1,8	6 x 1,8	6 x 1,8	8 x 1,8	8 x 1,8	8 x 1,8
		12.50	12.50	12.50	25.0	25.0	37.50	37.50	37.50	37.50	50.0	50.0	50.0
Fan Adedi x Çekilen Güç (kW) <i>Number of Fans x Power Input</i>		2 x 1,8	2 x 1,8	2 x 1,8	4 x 1,8	4 x 1,8	6 x 1,8	6 x 1,8	6 x 1,8	6 x 1,8	8 x 1,8	8 x 1,8	8 x 1,8
		12.50	12.50	12.50	25.0	25.0	37.50	37.50	37.50	37.50	50.0	50.0	50.0
Toplam Hava Debisi (m³/s) <i>Total Air Flowrate</i>		(1)	21.4	28.3	35.4	41.7	52.3	62.3	68.40	79.5	92.8	106.5	132.4
		(2)	19.4	25.6	32.0	37.7	47.4	56.4	61.90	71.9	84.0	96.4	119.8
Nominal Evaporatör Su Debisi (m³/h) <i>Nominal Evaporator Water Flowrate</i>		23	35	37	54	66	83	99	102	119	139	144	163
		8	14	16	16	18	23	23	23	28	28	28	40
Soğutucu Gaz Miktarı (kg) <i>Refrigerant Charge</i>		55	55	55	63	63	66	66	66	66	67	67	67
		1305	1560	1620	2075	2405	2925	3285	3480	3910	4265	4695	5015
Yağ Miktarı (lt) <i>Oil Charge</i>		8	14	16	16	18	23	23	23	28	28	40	40
Cihaz Ses Seviyesi dB(A) <i>Sound Pressure Level</i>		55	55	55	63	63	66	66	66	67	67	67	67
İşletme Ağırlığı ~ (kg) / Operating Weight		1305	1560	1620	2075	2405	2925	3285	3480	3910	4265	4695	5015

(1) 12°C su giriş, 7°C su çıkış ve 25°C dış hava sıcaklığına göre verilmiştir.

Values are based on evaporator entering/leaving water temp. 12°C/7°C and ambient temperature 25°C

(2) 12°C su giriş, 7°C su çıkış ve 33°C dış hava sıcaklığına göre verilmiştir.

Values are based on evaporator entering/leaving water temp. 12°C/7°C and ambient temperature 33°C

(3) Boş alanda 10 metre mesafedeki değerlere göre verilmiştir.

Values are based on freefield conditions in 10 meter distance.

Not: Gerekli şebeke gerilimi 3 faz-400 Volt-50 Hz' dir.

Note: Required power supply is 3 ph-400 Volt-50 Hz.

Kapasite Tablosu Capacity Table (KW)

SU ÇIKIŞI CHILLED WATER LEAVING	KONDENSERE HAVA GİRİŞ SICAKLIĞI / CONDENSER ENTERING AIR TEMP.																																							
	24 °C		26 °C		28 °C		30 °C		32 °C		34 °C		36 °C		38 °C		40 °C		42 °C		44 °C																			
	Q	No	Q	No	Q	No	Q	No	Q	No	Q	No	Q	No	Q	No	Q	No	Q	No	Q	No																		
EBHV - 113A.1	6	121.1	26.8	118.4	27.7	115.6	28.6	112.7	29.7	109.7	30.9	106.7	32.1	103.5	33.5	100.3	35.1	97.0	36.7	93.1	38.5	89.4	40.4																	
	7	125.9	27.1	123.1	27.9	120.2	28.9	117.3	29.9	114.2	31.1	111.1	32.4	107.9	33.8	104.6	35.3	101.1	37.0	97.2	38.8	93.4	40.7																	
	8	130.9	27.3	128.0	28.1	125.1	29.1	122.0	30.2	118.9	31.3	115.6	32.6	112.3	34.1	108.9	35.6	105.4	37.3	101.5	39.1	97.6	41.0																	
	9	136.0	27.5	133.1	28.3	130.0	29.3	126.9	30.4	123.6	31.6	120.3	32.9	116.9	34.3	113.4	35.9	109.8	37.5	106.1	39.3	101.8	41.3																	
	10	141.3	27.7	138.3	28.6	135.1	29.5	131.9	30.6	128.5	31.8	125.1	33.2	121.6	34.6	118.0	36.1	114.4	37.8	110.6	39.6	106.2	41.5																	
	11	146.8	27.9	143.6	28.8	140.3	29.8	137.0	30.9	133.6	32.1	130.1	33.4	126.5	34.8	122.8	36.4	119.0	38.1	115.1	39.9	110.7	41.8																	
	12	152.3	28.1	149.1	29.0	145.7	30.0	142.3	31.1	138.8	32.3	135.2	33.7	131.5	35.1	127.7	36.7	123.8	38.4	119.8	40.2	115.3	42.1																	
	13	158.1	28.3	154.7	29.2	151.3	30.2	147.8	31.3	144.1	32.6	140.4	33.9	136.6	35.4	132.8	36.9	128.8	38.6	124.7	40.5	120.5	42.4																	
	14	164.0	28.5	160.5	29.4	157.0	30.4	153.4	31.6	149.6	32.8	145.8	34.2	141.9	35.6	137.9	37.2	133.8	38.9	129.6	40.7	125.3	42.7																	
	15	170.1	28.7	166.5	29.6	162.9	30.6	159.1	31.8	155.3	33.0	151.4	34.4	147.4	35.9	143.3	37.5	139.1	39.2	134.8	41.0	130.4	43.0																	
	6	160.2	35.5	156.6	36.6	152.9	37.8	149.1	39.2	145.2	40.8	141.1	42.5	137.0	44.3	132.7	46.3	128.3	48.5	123.2	50.8	118.3	53.4																	
	7	166.6	35.7	162.9	36.9	159.1	38.1	155.2	39.5	151.1	41.1	147.0	42.8	142.7	44.7	138.3	46.7	133.8	48.9	128.7	51.2	123.6	53.7																	
	8	173.2	36.0	169.4	37.1	165.5	38.4	161.4	39.8	157.3	41.4	153.0	43.1	148.6	45.0	144.1	47.0	139.5	49.2	134.7	51.6	129.1	54.1																	
	9	180.0	36.3	176.1	37.4	172.0	38.7	167.9	40.2	163.6	41.7	159.2	43.5	154.7	45.3	150.1	47.4	145.3	49.6	140.4	52.0	134.7	54.5																	
	10	187.0	36.6	182.9	37.7	178.8	39.0	174.5	40.5	170.1	42.1	165.6	43.8	160.9	45.7	156.2	47.7	151.3	50.0	146.3	52.3	140.5	54.9																	
11	194.2	36.8	190.0	38.0	185.7	39.3	181.3	40.8	176.8	42.4	172.1	44.1	167.4	46.0	162.5	48.1	157.5	50.3	152.3	52.7	146.5	55.3																		
12	201.6	37.1	197.3	38.3	192.8	39.6	188.3	41.1	183.6	42.7	178.9	44.5	174.0	46.4	169.0	48.5	163.8	50.7	158.6	53.1	152.6	55.6																		
13	209.2	37.4	204.7	38.6	200.2	39.9	195.5	41.4	190.7	43.0	185.8	44.8	180.8	46.7	175.6	48.8	170.4	51.0	165.0	53.5	159.4	56.0																		
14	217.0	37.6	212.4	38.8	207.7	40.2	202.9	41.7	198.0	43.3	193.0	45.1	187.8	47.1	182.5	49.2	177.1	51.4	171.5	53.8	165.9	56.4																		
15	225.0	37.9	220.3	39.1	215.5	40.5	210.5	42.0	205.5	43.6	200.3	45.4	195.0	47.4	189.6	49.5	184.0	51.8	178.3	54.2	172.5	56.8																		
6	200.1	42.2	195.6	43.5	190.9	45.0	186.2	46.6	181.3	48.5	176.3	50.5	171.1	52.7	165.7	55.1	160.2	57.7	154.6	60.5	147.9	63.4																		
7	208.1	42.5	203.4	43.8	198.7	45.3	193.8	47.0	188.7	48.8	183.6	50.9	178.2	53.1	172.8	55.5	167.1	58.1	161.3	60.9	154.6	63.9																		
8	216.3	42.8	211.5	44.2	206.6	45.7	201.6	47.4	196.4	49.2	191.1	51.3	185.6	53.5	180.0	55.9	174.2	58.5	168.2	61.3	161.4	64.4																		
9	224.8	43.1	219.9	44.5	214.8	46.0	209.6	47.7	204.3	49.6	198.8	51.7	193.2	53.9	187.4	56.4	181.5	59.0	175.4	61.8	168.4	64.8																		
10	233.5	43.5	228.4	44.9	223.2	46.4	217.9	48.1	212.4	50.0	206.8	52.1	201.0	54.3	195.0	56.8	189.0	59.4	182.7	62.2	176.3	65.3																		
11	242.5	43.8	237.2	45.2	231.9	46.7	226.4	48.5	220.7	50.4	215.0	52.5	209.0	54.7	202.9	57.2	196.7	59.8	190.2	62.7	183.6	65.7																		
12	251.7	44.1	246.3	45.5	240.8	47.1	235.1	48.8	229.3	50.8	223.4	52.9	217.3	55.1	211.0	57.6	204.6	60.3	198.0	63.1	191.2	66.2																		
13	261.2	44.4	255.7	45.8	250.0	47.4	244.1	49.2	238.2	51.1	232.0	53.3	225.8	55.6	219.3	58.0	212.7	60.7	206.0	63.6	199.1	66.6																		
14	271.0	44.7	265.3	46.2	259.4	47.8	253.4	49.6	247.3	51.5	241.0	53.6	234.5	56.0	227.9	58.4	221.1	61.1	214.2	64.0	207.1	67.1																		
15	281.0	45.0	275.1	46.5	269.1	48.1	262.9	49.9	256.6	51.9	250.1	54.0	243.5	56.4	236.7	58.9	229.8	61.6	222.7	64.4	215.4	67.5																		

N₀= Kompresör mil gücü (kW) Power input

Q₀= Soğutma kapasitesi (kW) Cooling capacity

Kapasite Tablosu Capacity Table (KW)

CİHAZ TİPİ TYPE	SU ÇIKIŞI CHILLED WATER LEAVING	KONDENSERE HAVA GİRİŞ SICAKLIĞI / CONDENSER ENTERING AIR TEMP.																							
		24 °C		26 °C		28 °C		30 °C		32 °C		34 °C		36 °C		38 °C		40 °C		42 °C		44 °C			
		Q	No	Q	No	Q	No	Q	No	Q	No	Q	No	Q	No	Q	No	Q	No	Q	No	Q	No		
EBHV - 360A.1	6	386.6	82.4	378.0	85.0	369.0	87.9	359.9	91.1	350.4	94.7	340.7	98.6	330.6	102.9	320.3	107.6	309.7	112.7	297.7	118.1	285.9	124.0		
	7	402.1	83.0	393.2	85.6	384.0	88.6	374.5	91.8	364.8	95.5	354.8	99.4	344.5	103.8	333.9	108.5	323.0	113.5	311.8	119.0	298.7	124.9		
	8	418.0	83.7	408.8	86.3	399.3	89.3	389.6	92.6	379.6	96.2	369.3	100.2	358.7	104.6	347.8	109.3	336.6	114.4	325.1	119.9	311.9	125.8		
	9	434.4	84.3	424.9	87.0	415.2	90.0	405.1	93.3	394.8	97.0	384.2	101.0	373.4	105.4	362.2	110.1	350.7	115.2	338.9	120.7	325.5	126.6		
	10	451.3	84.9	441.5	87.6	431.4	90.7	421.1	94.0	410.5	97.7	399.6	101.8	388.4	106.2	377.0	110.9	365.2	116.1	353.1	121.6	339.4	127.5		
	11	468.6	85.6	458.5	88.3	448.2	91.4	437.5	94.7	426.6	98.5	415.4	102.5	404.0	107.0	392.2	111.8	380.1	116.9	367.7	122.5	354.9	128.4		
	12	486.5	86.2	476.1	88.9	465.4	92.0	454.5	95.4	443.2	99.2	431.7	103.3	419.9	107.8	407.8	112.6	395.4	117.8	382.7	123.3	369.6	129.3		
	13	504.9	86.8	494.1	89.6	483.1	92.7	471.8	96.2	460.3	99.9	448.5	104.1	436.4	108.6	423.9	113.4	411.2	118.6	398.1	124.2	384.7	130.2		
	14	523.7	87.4	512.7	90.2	501.3	93.4	489.7	96.9	477.9	100.7	465.7	104.8	453.2	109.3	440.5	114.2	427.4	119.4	414.0	125.1	400.3	131.1		
	15	543.2	88.0	531.7	90.9	520.1	94.0	508.1	97.6	495.9	101.4	483.4	105.6	470.6	110.1	457.5	115.0	444.1	120.3	430.4	125.9	416.3	131.9		
	6	449.3	92.3	439.2	95.2	428.8	98.4	418.1	102.1	407.1	106.1	395.8	110.5	384.2	115.3	372.2	120.6	359.9	126.3	347.1	132.4	332.5	138.9		
	7	467.2	93.0	456.8	96.0	446.2	99.2	435.2	102.9	423.9	107.0	412.2	111.4	400.3	116.3	388.0	121.5	375.3	127.2	362.3	133.3	347.4	139.9		
	8	485.7	93.8	475.0	96.7	464.0	100.0	452.7	103.7	441.1	107.8	429.1	112.3	416.8	117.2	404.2	122.5	391.2	128.2	377.8	134.3	362.7	140.9		
	9	504.8	94.5	493.7	97.5	482.4	100.8	470.7	104.5	458.8	108.6	446.5	113.1	433.8	118.1	420.9	123.4	407.5	129.1	393.8	135.3	379.7	141.9		
	10	524.4	95.2	513.0	98.2	501.3	101.6	489.3	105.3	477.0	109.5	464.3	114.0	451.4	119.0	438.0	124.3	424.3	130.1	410.3	136.3	395.8	142.9		
11	544.5	95.9	532.8	98.9	520.8	102.4	508.4	106.1	495.7	110.3	482.7	114.9	469.4	119.8	455.7	125.2	441.6	131.0	427.2	137.2	412.4	143.9			
12	565.3	96.6	553.2	99.7	540.8	103.1	528.1	106.9	515.0	111.2	501.6	115.7	487.9	120.7	473.9	126.1	459.5	132.0	444.7	138.2	429.5	144.9			
13	586.6	97.2	574.1	100.4	561.4	103.9	548.3	107.7	534.9	112.0	521.1	116.6	507.0	121.6	492.6	127.1	477.8	132.9	462.6	139.2	447.0	145.8			
14	608.6	97.9	595.7	101.1	582.5	104.6	569.1	108.5	555.3	112.8	541.1	117.5	526.7	122.5	511.8	128.0	496.6	133.8	481.1	140.1	465.1	146.8			
15	631.1	98.6	617.9	101.8	604.3	105.4	590.4	109.3	576.2	113.6	561.7	118.3	546.8	123.4	531.6	128.9	516.0	134.8	500.1	141.1	483.7	147.8			
6	524.9	109.0	513.1	112.4	501.0	116.2	488.5	120.5	475.7	125.3	462.5	130.5	448.9	136.2	434.9	142.4	420.4	149.1	405.6	156.3	388.3	164.0			
7	545.9	109.9	533.7	113.3	521.3	117.2	508.4	121.5	495.2	126.3	481.6	131.5	467.6	137.3	453.3	143.5	438.5	150.2	423.2	157.5	405.8	165.2			
8	567.5	110.7	555.0	114.2	542.1	118.1	528.9	122.5	515.3	127.3	501.3	132.6	487.0	138.3	472.2	144.6	457.0	151.3	441.4	158.6	423.7	166.4			
9	589.8	111.6	576.8	115.1	563.6	119.0	550.0	123.4	536.0	128.3	521.6	133.6	506.9	139.4	491.7	145.7	476.1	152.5	460.1	159.8	442.1	167.6			
10	612.6	112.4	599.3	116.0	585.7	120.0	571.7	124.4	557.3	129.3	542.5	134.6	527.3	140.5	511.8	146.8	495.8	153.6	479.3	160.9	462.5	168.7			
11	636.2	113.2	622.5	116.8	608.4	120.9	594.0	125.3	579.2	130.3	564.0	135.7	548.4	141.5	532.4	147.9	516.0	154.7	499.1	162.0	481.8	169.9			
12	660.4	114.0	646.3	117.7	631.8	121.8	616.9	126.3	601.7	131.3	586.1	136.7	570.1	142.6	553.6	149.0	536.8	155.8	519.5	163.2	501.8	171.1			
13	685.4	114.8	670.8	118.5	655.9	122.7	640.6	127.2	624.9	132.2	608.8	137.7	592.4	143.6	575.5	150.0	558.2	156.9	540.5	164.3	522.3	172.2			
14	711.0	115.6	696.0	119.4	680.6	123.5	664.9	128.2	648.7	133.2	632.2	138.7	615.3	144.7	598.0	151.1	580.2	158.0	562.0	165.5	543.4	173.4			
15	737.4	116.4	721.9	120.2	706.0	124.4	689.8	129.1	673.3	134.2	656.3	139.7	638.9	145.7	621.1	152.2	602.9	159.1	584.2	166.6	565.1	174.6			

Q= Soğutma kapasitesi (kW) Cooling capacity

N_k= Kompresör mil gücü (kW) Power input

Kapasite Tablosu Capacity Table (KW)

CIHAZ TIPI TYPE	SU ÇIKIŞI CHILLED WATER LEAVING	KONDENSERE HAVA GİRİŞ SICAKLIĞI / CONDENSER ENTERING AIR TEMP.																																																																																																																																																																																																																																																																																																																																																																																																																																																																																																																																																																																																																																																																																			
		24 °C			26 °C			28 °C			30 °C			32 °C			34 °C			36 °C			38 °C			40 °C			42 °C			44 °C																																																																																																																																																																																																																																																																																																																																																																																																																																																																																																																																																																																																																																																					
		Q	No	Q	No	Q	No	Q	No	Q	No	Q	No	Q	No	Q	No	Q	No	Q	No	Q	No	Q	No	Q	No	Q	No	Q	No	Q	No	Q	No																																																																																																																																																																																																																																																																																																																																																																																																																																																																																																																																																																																																																																																		
EBHV - 560A.1	6	602.2	122.1	588.7	125.9	574.8	130.2	560.4	135.0	545.7	140.3	530.6	146.1	514.9	152.5	498.9	159.5	482.3	167.0	465.3	175.0	445.8	183.7	626.3	123.0	612.3	126.9	598.0	131.2	583.3	136.1	568.1	141.4	552.5	147.3	536.5	153.7	520.0	160.7	503.0	168.2	485.5	176.3	465.7	185.0	651.1	124.0	636.7	127.9	621.9	132.3	606.8	137.1	591.2	142.5	575.1	148.5	558.7	154.9	541.7	161.9	524.3	169.5	506.4	177.6	488.0	186.3	676.6	124.9	661.8	128.9	646.6	133.3	630.9	138.2	614.9	143.7	598.4	149.6	581.5	156.1	564.1	163.1	546.2	170.7	527.8	178.9	508.9	187.6	702.8	125.9	687.6	129.8	671.9	134.3	655.8	139.3	639.3	144.8	622.4	150.8	605.0	157.3	587.1	164.4	568.8	172.0	549.9	180.2	530.5	188.9	729.9	126.8	714.1	130.8	698.0	135.3	681.4	140.4	664.4	145.9	647.0	151.9	629.1	158.5	610.8	165.6	592.0	173.2	572.6	181.4	552.8	190.2	757.7	127.7	741.4	131.8	724.8	136.3	707.8	141.4	690.3	147.0	672.4	153.0	654.0	159.6	635.2	166.8	615.8	174.5	596.0	182.7	575.6	191.5	786.3	128.6	769.5	132.7	752.4	137.3	734.9	142.5	716.9	148.1	698.5	154.2	679.6	160.8	660.2	168.0	640.4	175.7	620.0	184.0	599.2	192.9	815.7	129.5	798.4	133.7	780.8	138.3	762.7	143.5	744.2	149.1	725.3	155.3	705.9	162.0	686.0	169.2	665.7	177.0	644.8	185.3	623.4	194.2	845.9	130.4	828.1	134.6	810.0	139.3	791.4	144.5	772.4	150.2	752.9	156.4	733.0	163.2	712.5	170.4	691.6	178.2	670.2	186.5	648.3	195.5	678.4	138.6	663.2	142.9	647.5	147.8	631.4	153.2	614.8	159.3	597.7	165.9	580.1	173.2	562.0	181.0	543.4	189.6	524.2	198.7	502.1	208.6	705.5	139.7	689.8	144.1	673.7	149.0	657.1	154.5	640.0	160.6	622.5	167.2	604.4	174.5	585.8	182.4	566.7	191.0	547.0	200.2	524.6	210.1	733.5	140.8	717.3	145.2	700.7	150.2	683.6	155.7	666.0	161.8	648.0	168.6	629.4	175.9	610.3	183.8	590.7	192.4	570.5	201.6	547.8	211.5	762.2	141.8	745.5	146.3	728.4	151.3	710.8	156.9	692.7	163.1	674.2	169.9	655.1	177.2	635.5	185.2	615.4	193.8	594.7	203.1	573.4	213.0	791.8	142.9	774.6	147.4	757.0	152.5	738.9	158.2	720.3	164.4	701.2	171.2	681.6	178.6	661.4	186.6	640.8	195.3	619.5	204.6	597.7	214.5	822.3	143.9	804.5	148.5	786.3	153.7	767.7	159.4	748.6	165.6	728.9	172.5	708.8	179.9	688.1	188.0	666.9	196.7	645.1	206.0	622.8	216.0	853.6	145.0	835.3	149.6	816.6	154.8	797.4	160.6	777.7	166.9	757.5	173.8	736.8	181.3	715.6	189.4	693.8	198.1	671.4	207.5	648.5	217.5	885.8	146.0	867.0	150.7	847.7	155.9	827.9	161.7	807.6	168.1	786.9	175.1	765.6	182.6	743.8	190.7	721.5	199.5	698.5	208.9	675.0	219.0	918.9	147.0	899.5	151.8	879.6	157.1	859.3	162.9	838.5	169.3	817.1	176.3	795.3	183.9	772.9	192.1	749.9	200.9	726.4	210.4	702.3	220.5	953.0	148.0	933.0	152.8	912.5	158.2	891.6	164.1	870.1	170.6	848.2	177.6	825.8	185.2	802.8	193.5	779.2	202.3	755.1	211.8	730.4	221.9	748.4	152.1	731.6	156.9	714.3	162.2	696.5	168.2	678.2	174.8	659.4	182.1	640.0	190.1	620.0	198.7	599.4	208.1	578.3	218.1	554.0	228.9	778.3	153.3	761.0	158.1	743.2	163.5	724.9	169.6	706.1	176.2	686.7	183.6	666.7	191.6	646.2	200.3	625.1	209.6	603.4	219.7	578.8	230.6	809.1	154.5	791.3	159.4	772.9	164.8	754.1	170.9	734.7	177.6	714.8	185.0	694.3	193.1	673.2	201.8	651.6	211.2	629.3	221.3	606.4	232.2	840.8	155.7	822.4	160.6	803.5	166.1	784.1	172.3	764.2	179.0	743.7	186.5	722.7	194.5	701.0	203.3	678.8	212.8	656.0	222.9	632.5	233.8	873.5	156.8	854.5	161.8	835.0	167.4	815.1	173.6	794.5	180.4	773.5	187.9	751.9	196.0	729.6	204.8	706.8	214.3	683.4	224.5	659.4	235.4	907.1	158.0	887.5	163.0	867.5	168.7	846.9	174.9	825.8	181.8	804.1	189.3	781.9	197.5	759.1	206.3	735.7	215.9	711.7	226.1	687.0	237.1	941.6	159.1	921.5	164.2	900.8	169.9	879.6	176.2	857.9	183.2	835.6	190.7	812.8	199.0	789.4	207.9	765.3	217.4	740.7	227.7	715.4	238.7	977.2	160.3	956.4	165.4	935.1	171.2	913.3	177.5	890.9	184.5	868.0	192.1	844.6	200.4	820.5	209.4	795.9	219.0	770.6	229.3	744.7	240.3	1,013.7	161.4	992.3	166.6	970.4	172.4	947.9	178.8	924.9	185.9	901.4	193.6	877.3	201.9	852.6	210.9	827.3	220.5	801.3	230.9	774.8	242.0	1,051.3	162.5	1,029.2	167.8	1,006.6	173.6	983.5	180.1	959.9	187.2	935.7	194.9	910.9	203.3	885.6	212.4	859.6	222.1	833.0	232.5	805.7	243.6
	EBHV - 630A.1																																																																																																																																																																																																																																																																																																																																																																																																																																																																																																																																																																																																																																																																																				
	EBHV - 695A.1																																																																																																																																																																																																																																																																																																																																																																																																																																																																																																																																																																																																																																																																																				

N_c= Kompresör mil gücü (kW) Power input

Q= Soğutma kapasitesi (kW) Cooling capacity

Boyutlar Dimensions

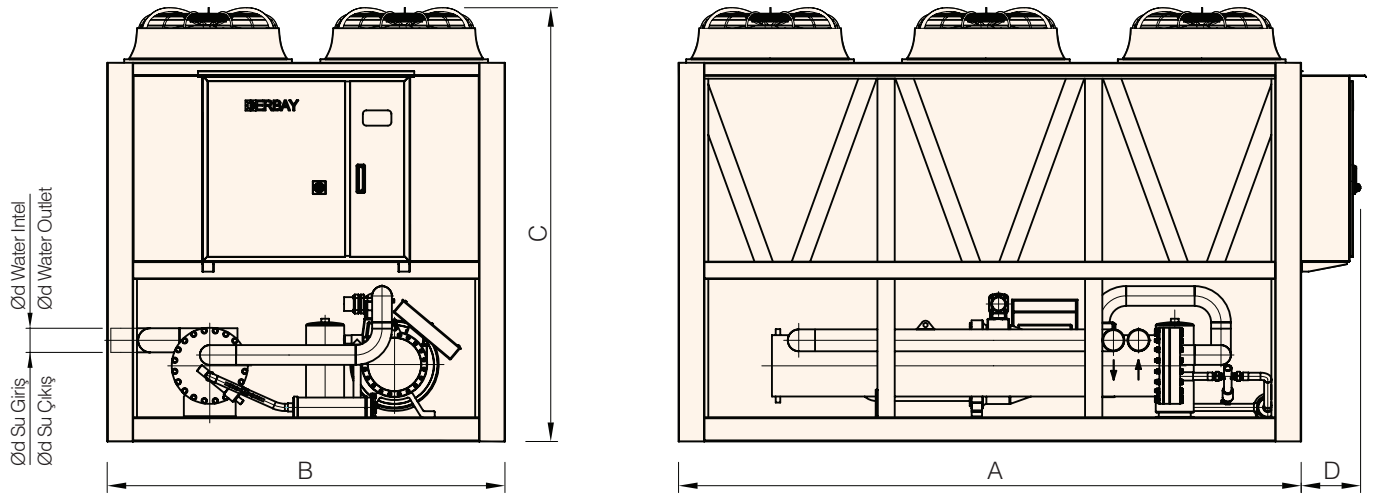

TİP TYPE	EBHV- 113A.1	EBHV- 150A.1	EBHV- 185A.1	EBHV- 220A.1	EBHV- 275A.1	EBHV- 330A.1	EBHV- 360A.1	EBHV- 420A.1	EBHV- 490A.1	EBHV- 560A.1	EBHV- 630A.1	EBHV- 695A.1
A	1300	1300	1300	2400	2400	3600	3600	3600	3600	4800	4800	4800
B	2250	2250	2250	2250	2250	2250	2250	2250	2250	2250	2250	2250
C	2380	2480	2480	2505	2625	2625	2690	2690	2690	2690	2790	2790
D	375	375	375	375	375	400	400	400	400	400	400	400
d	DN65	DN80	DN100	DN100	DN125	DN125	DN125	DN150	DN150	DN150	DN200	DN200

Boyutlar Dimensions

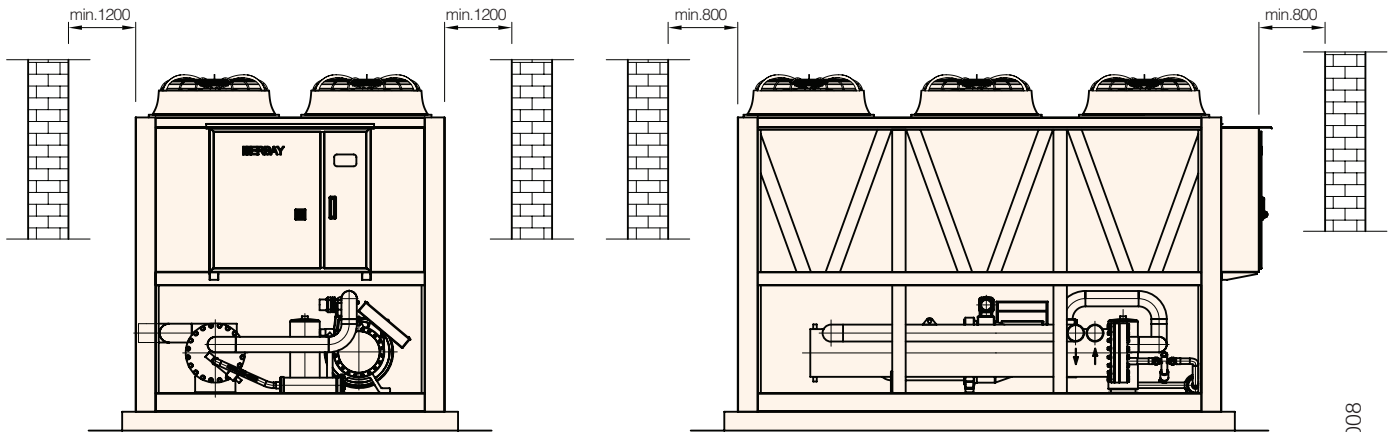

Not : Ölçü ve dizayn deęiřtirme hakkımız mahfuzdur.

Note : We reserve the right to make changes in dimensions and design at any time, without notice



ERBAY SOĐUTMA İKLİMLENDİRME CİHAZLARI SAN VETİC. A.Ş.

Deliklikaya Mahallesi

Alpdağ Cad. No:37 34555

Arnavutköy / İSTANBUL / TÜRKİYE

Tel : (+90) 212 623 24 92 Pbx

Fax : (+90) 212 623 24 96

E-mail : erbay@erbay.com.tr

sales@erbay.com.tr www.erbay.com.tr